



879642000378



DIVE RITE[®]
EQUIPMENT FOR SERIOUS DIVERS

Deluxe Harness

Item # BC1080

Packaging contains:

- 1) 6-ft of 2" harness webbing,
with stainless-steel grommet
- 2) 6 stainless steel 2-inch belt slides
- 3) 2 4.5-ft sections of harness webbing,
with pivot rings
- 4) 2 Stainless steel 2-inch D-rings
- 5) 2 Stainless steel 2-inch bent D-rings
- 6) 1 Stainless steel 2-inch
waist-strap release belt
buckle
- 8) Left and right 1-inch chest strap
assembly

This harness utilizes nylon webbing
for strength and comfort.

This Dive Rite harness fits on
all Dive Rite backplates.

Specifically designed for technical
diving with a rigid backplate, swivel
points on the shoulder straps and
a chest strap to ensure a comfortable
fit.

**** Crotch Strap not included****

www.DiveRite.Com

©2021 Lamartek, Inc. dba Dive Rite
175 NW Washington St.
Lake City, FL 32055 USA

Threading Deluxe Harness

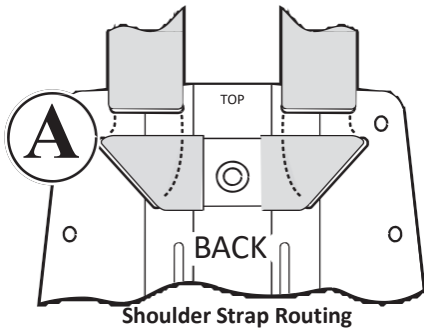

Shoulder Strap Routing

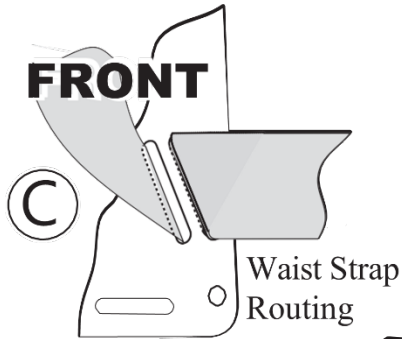

Waist Strap Routing

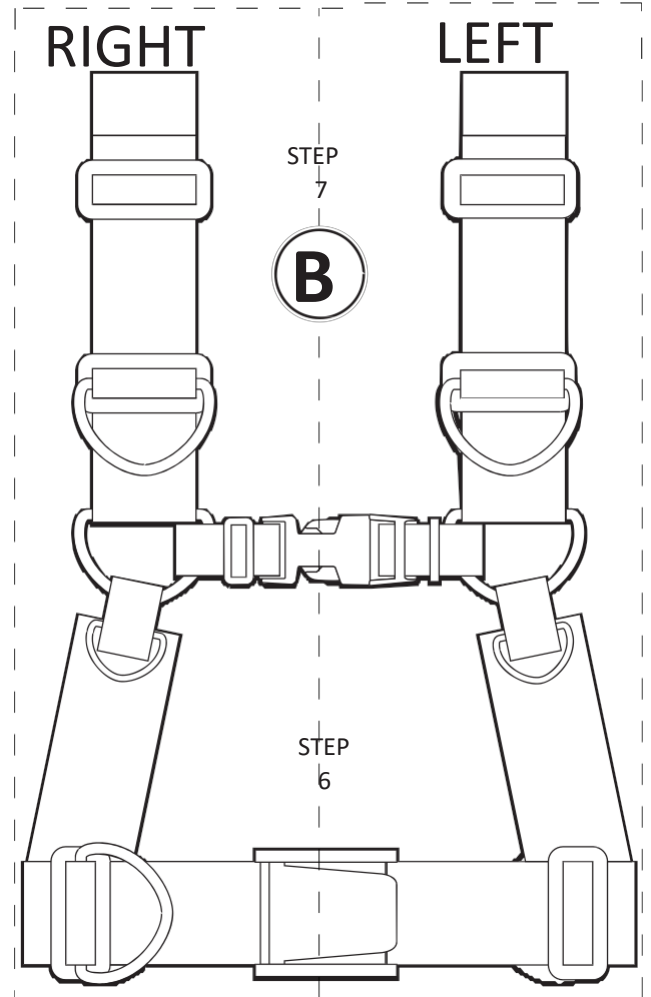
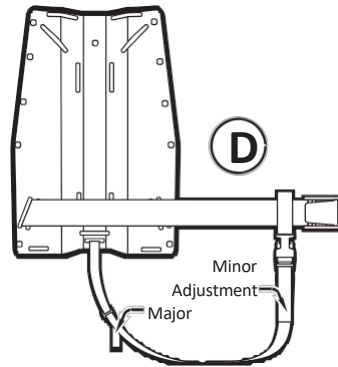

- 1) Thread the 6-foot webbing piece through the upper shoulder strap slots, as shown in Figure A, positioning the webbing so the grommet is over the upper tank bolt-hole on the backplate.
- 2) Using one waist strap assembly, weave the tail end through the two left (as you are looking at the front of the back plate) waist slots - starting from the front, through the inner slot, and back out through the outer slot again.
- 3) Repeat step 3 on the right side with the second waist-strap assembly.
- 4) Using Figure B, install one 2" belt slide and one 2" D-ring on each tail of waist straps.
- 5) Install one 2-inch belt slide on each shoulder strap.
- 6) Install one 2" belt slide with one 2" bent "D"-ring on each shoulder strap.
- 7) Weave the tail of each shoulder strap through the corresponding pivot ring located on the waist strap as shown. Then weave the webbing back through both 2" belt slides.
- 8) Using right chest-strap assembly (with buckle), loop webbing through right-side pivot-ring and weave back through belt slide.
- 9) Using left chest-strap assembly, loop webbing through left-side pivot-ring and pull tail through ring.
- 10) Weave tail of left chest-strap assembly through the slots in the quick-release buckle of the right-side chest-strap assembly.
- 11) Install the optional crotch strap components (not included) as shown in figure "D".
- 12) Install the waist-strap release buckle on the same side of the waist-strap as the crotch-strap loop is installed.