



www.DiveRite.com

LT6250LED-LUX LT6500LED-LUX LED Canister Light

Product Description



LT6250LED-LUX, Goodman Handle

The LED-LUX light has a compact LED light head with up to 1000 lumens of illumination, featuring the excellent robust nature of LED technology. The head has an attachment point for a clip so it can be clipped to a BC or harness, and comes standard with an elastic hand-mount or optional Goodman handle. The light is available with either the Slimline battery pack/canister or the Quest battery pack/canister.

Cautions

- Turn your light off if it dims significantly, or you risk permanent battery damage.
- Disconnect your light head from the battery pack when traveling. If the light accidentally turns on, the light head could overheat and cause damage to the light head or potentially cause a fire.
- The output of your light is extremely bright and may cause eye damage.
- Your light is designed for underwater use. Water provides cooling. Running the light out of the water can cause the light head to get extremely hot.

Cycling A New Battery

The NiMH battery needs to be properly conditioned. Also if you've had your light for awhile and the battery is no longer getting its full burn time, cycling the battery will often recover any lost burn-time. This is done through a complete 3-5 time charge and discharge until the rated burn time is achieved.

To cycle a NiMH battery:

1. Fully charge the battery by connecting the battery to the charger *first* and then plugging the charger into the outlet.
2. Once the battery is fully charged, assemble the light and then place the light head in a sink or bucket of water to dissipate the heat
3. Allow the light head to completely discharge until it goes out and then turn it off immediately. Never leave the light turned-on after the battery has fully discharged.
4. Charge the battery and repeat the same discharge cycle. How many cycles the battery needs is up to individual difference in the battery. It should need between 3-5 cycles. As long as the burn time increases, keep cycling.

Charge the battery regularly. Put the battery on a charger at least once a month if it hasn't been dived. This will keep the battery conditioned and ready.



LT6500LED-LUX, Quest Canister

Charging The Battery

Before using your light, make sure the battery is fully cycled.

Battery charging notes:

- The battery may not attain full burn time until you have charged and discharged the battery several times. The battery needs to be cycled (charged and discharged) three to five times before maximum burn times are reached.
- Flickering of the light before maximum burn time is reached is an indication that the battery has either not been fully charged or that the battery has not been charged and discharged enough times (see note above). If the light begins flickering, turn it off immediately and recharge the battery.

To Charge the Battery:

1. Remove the battery from the canister.
2. Connect the charger plug into the battery pack plug.
3. Plug the charger into a wall outlet.
4. Allow the battery to fully charge. The LED on the charger indicates when the battery is fully charged. The red LED senses power. The green LED flashes three times to sense battery voltage, rapid flashes while charging the battery, and is on steady when the battery is fully charged.
5. Unplug the charger from the wall socket.
6. Disconnect the charger from the battery.

Maintaining The Battery

The battery is maintenance free. After each dive, you should fully re-charge the battery. It does not matter how much or how little you use the battery during a dive. The battery will not develop a memory of a particular dive time.

You should avoid fully discharging the battery (a condition known as deep discharge). To avoid battery damage due to deep discharge, follow the burn time specifications on this data sheet. Keep light usage within the time listed. This greatly extends battery life.

Note: Refer to Dive Rite's website for more information about making your battery last.

Pre-Dive Inspection

Prior to taking the light underwater, ensure that all o-rings and latches on your light are secure.

Post Dive Care

- Inspect the light head for any leakage or other damage
- Rinse the light head thoroughly in fresh water and allow it to dry.

Inserting The Battery Pack

The battery pack sits vertically in the canister with the power cable extending from the top of the canister.

To insert the battery pack:

1. Align the bottom of the battery pack with the top of the canister.
2. Slide the battery pack into the canister. Do not drop the battery into the canister.
3. Orient the power cable so that it is not pinched or obstructed in any way.

Attaching The Canister Lid

The canister lid must be firmly attached to the canister using the locking latches on the side of the canister.

To attach the canister lid:

1. Inspect the o-ring for any dirt or grease and clean the o-ring if necessary with soap and water.
2. Plug the canister lid cable connector into the battery cable connector.
3. Tuck the connectors and wiring harness inside the canister.
4. Place the lid onto the top of the canister making sure the o-ring rests on the top of the canister and the lid latch attachments align with the locking latches.
5. Close and seal the lid using the locking latches. Close the latches simultaneously to evenly seal the o-ring.

Dealing With A Flooded Light-Head

Determining if a light is flooded can be as obvious as pouring water out of your canister or as subtle as seeing a small amount of water in the lens.

What to do: If your light head floods, do not continue to use the light. Turn the light off and disconnect the battery pack. **DO NOT TAKE THE LIGHT APART!** Arrange with your dealer to return the light to Dive Rite for repair. Flooding damage cannot be fixed or corrected in the field. Trying to repair the light in the field can void your warranty.

Dealing with a flooded light head:

1. Turn the light off. The longer current flows, the more damage can take place.
2. Disconnect and remove the battery from the canister.
3. Pour out any water from the canister, and allow to dry.
4. Return all affected parts back to Dive Rite for repair.

Mounting The Canister

The canister can be waist mounted on any standard BC harness, TransPac harness, or to the side of a dive tank.

Waist-mounting the canister

The canister is equipped with a webbing loop for waist mounting the canister to a BC harness. You will need a standard cam-style buckle to waist mount your light.

To waist-mount the canister:

1. Slide the BC or backpack waist harness through the webbing loop slot on the canister.
2. Position the canister on the waist harness on your hip so that it is comfortable and easy for you to access.
3. Slide the cam buckle onto the waist harness up to the light's webbing loop.
4. Cam the buckle in place. This keeps the canister from sliding on the waist harness.

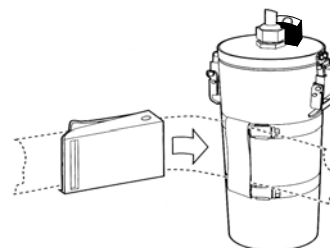

Tank-mounting the canister

The webbing loop on the canister can be used to attach to a 2-inch (50 mm) tank BC cam strap. This is a good method for mounting a light to a single tank. If your tank cam strap is not suited for holding a heavy light, you can use a separate 2-inch cam strap (P/N 2032) to secure the light to the tank.

To tank-mount the canister:

1. Position the canister so that the light cord is facing down, towards the bottom of the tank. This allows you to route the light cord next to your waist.
2. Place the canister on the right-hand side of the tank.
3. Slide the cam strap webbing through the canister webbing loop. Position the canister as close to your body as possible.
4. Wrap the cam strap around the tank and secure it using the cam strap buckle.

TransPac mounting the canister

You can attach the canister to a TransPac using two of the D-rings on the backside of the TransPac harness. There are a number of different ways to attach the canister to the D-rings, such as double-ended bolt snaps, carabiners, surgical tubing, etc. Your body size and desired position of the canister will control what hardware you need and how you use the hardware.

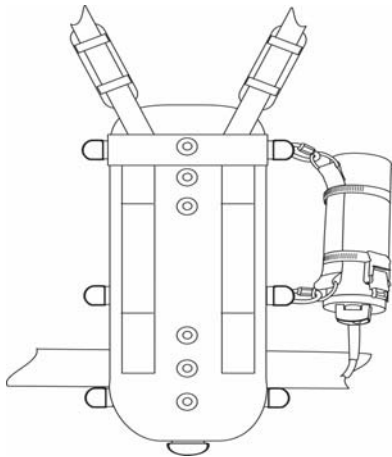

Specifications

LED-LUX Light Head

Lens: Flat glass port
Bulb: 3 LED (Light Emitting Diodes Array)
Color temperature: 6,500 degrees Kelvin
Bulb life: to ten-thousand hours
Burn-time: 6-hours Slimline or 8-10 hours Quest
Size:
Length: 4 in. (10.16 cm)
Diameter: 2 in. (5.08 cm)

Slimline NiMH Battery & Charger

Battery pack
Rating: 12 V, 4500 mA NiMH
Burn time: 6 hours
Plug: Standard 2-pole trailer plug

Note: To obtain maximum burn times, the batteries must be cycled 4 to 6 times before the cells are at peak performance. During the first few charge and discharge cycles, burn times may not reach the full rate.

Charger

Rating: 120/220 VAC, auto sensing
Indicators: Red and green LED
Plugs: Standard 2-pole trailer plug and a standard 2-pronged wall outlet plug

Quest NiMH Battery & Charger

Battery pack

Rating: 12 V, 10,000 mA NiMH
Burn time: : 8-10 hours
Plug: Standard 2-pole trailer plug

Note: To obtain maximum burn times, the batteries must be cycled 4 to 6 times before the cells are at peak performance. During the first few charge and discharge cycles, burn times may not reach the full rate.

Charger

Rating: 120/220 VAC, auto sensing
Indicators: Red and green LED
Plugs: Standard 2-pole trailer plug and a standard 2-pronged wall outlet plug

Light Canisters

The Light Canisters are formed from a single piece of extruded poly-vinyl chloride pipe (PVC). The PVC material and round design make it extremely strong under extreme pressure. The canister lid contains the power cable that connects the light head to the NiMH batteries, an on/off power switch with protector, an o-ring seal, which keeps water from entering the canister, and compression style locking latches, which prevents accidental opening of the latches. The canister webbing loop is used to mount the canister to a BC or harness.

Slimline Light Canister Size:

Height: 9 inches (22.86 cm)
Diameter: 2.6 inches (6.60 cm)
Weight: 3.8 pounds (1.72 kg) with battery, -1.25 pounds (-0.56 kg) negative in freshwater
Canister seal: single compression style o-ring
Canister locking: compression style locking latches
Mounting: 2-inch belt loop, webbing
Switch: Canister mounted toggle switch with switch protector
Battery size: 12 V, 4500 mA NiMH
Depth rating: 500 feet (152 m)

Quest Light Canister Size:

Height: 8.25 inches (21.00 cm)
Diameter: 4.00 inches (10.25 cm)
Weight: 5.5 pounds (2.49 kg) with battery. 1.9 lb (1.1 kg) negative in freshwater
Canister seal: single compression style o-ring
Canister locking: compression style locking latches
Mounting: 2-inch belt loop, webbing
Switch: Canister mounted toggle switch with switch protector
Battery size: 12 V, 10,000 mA NiMH
Depth rating: 500 feet (152 m)

DEVELOPED BY

Dive Rite
175 NW Washington Street
Lake City, FL 32055
Phone: 386.752.1087
Fax: 386.755.0613
Web: www.DiveRite.com

COPYRIGHT NOTICE

Copyright © 2009 Lamartek, Inc. dba Dive Rite

This manual is copyrighted by Lamartek, Inc. dba Dive Rite. You may not reproduce, translate, transcribe, or transmit any part of this manual without express, written permission from Lamartek, Inc. dba Dive Rite.

LIMITED WARRANTY

Lamartek, Inc. dba Dive Rite will — at its sole discretion — repair or replace dive light components proved to be damaged by faulty manufacture or material, at no cost, for a period of up to one year (365 days) from the date of purchase.

ALL WARRANTY CLAIMS MUST BE RETURNED TO THE STORE WHERE PURCHASED OR DIRECTLY TO DIVE RITE. A COPY OF THE PURCHASE RECEIPT MUST BE INCLUDED WITH THE PRODUCT.

- Canister bodies and the metal portions of light heads are warranted for the life of the product.
- Batteries are warranted against defects in manufacture or material for of up to 90 days from date of purchase. This warranty does not cover loss of battery “burn time” — a condition that results almost exclusively from mis-use or abuse. Users must read and study the rated “burn time” information appearing in Dive Rite’s website. Failure to do so can easily result in expensive damage not covered under warranty.
- Attempting to charge damaged batteries can further result in damage to chargers. This is not covered under warranty — nor is damage to chargers caused by nonstandard alternating current voltages or cycle rates. Chargers returned under warranty must be accompanied by the battery they were being used to charge. If the battery is determined to be the cause of charger damage, no warranty coverage will be provided.
- The warranty also specifically excludes bulbs, lenses, fuses, O-rings, or other conditions ***resulting from misuse, negligence, failure to properly lubricate o-rings, alteration, accident, or unauthorized repair.***
- If you have any problems with the light-head (ie, flood, etc), do not continue to use the light. Arrange with your dealer to return the light to Dive Rite for repair. Flood damage can not be fixed in the field. ***Opening the light head will void your warranty.***
- This warranty applies only to the original retail purchaser. It does not cover commercial or rental use, nor does it extend to units purchased from other than an authorized Dive Rite dealer.
- To make a claim under this warranty, the owner must have registered his/her warranty using Dive Rite’s website (www.diverite.com). All warranty repairs (international or domestic) *must* be accompanied by a copy of the purchase receipt. For warranty repairs (international or domestic) the product must be returned to the *store* where the item was purchased or directly to Dive Rite. A Return Authorization must be obtained by calling Dive Rite corporate offices (386-752-1087) to send items to Dive Rite. No warranty service will be performed for other than registered owners.

Note: Local dealers and distributors are not responsible for service of items purchased from unauthorized dealers, internet dealers, or dealers from other territories.

- This warranty becomes void if dive light components are damaged by anything other than normal recreational diving use, or if they have been serviced or repaired by other than authorized Dive Rite dealers.
- Repairs made under this warranty will not extend the warranty period.
- All further claims, especially for damage after diving accidents, are excluded from coverage under this warranty.
- Lamartek, Inc., dba Dive Rite, has no obligation to honor any extension of this warranty.

All Dive Rite light systems are pressure and burn tested at the factory prior to delivery. When light systems are returned to Dive Rite for warranty service, the first thing we do is assemble the light precisely as outlined in this manual, including proper lubrication and installation of o-rings. We then pressure test the light, just as we did when it was new. If the light passes this second pressure test, we have to assume that any reported flooding must have resulted from failure to properly assemble and/or maintain the light as outlined in this manual — in which case no warranty coverage is provided.
